

Assembly Manual

Building a Freedom Toaster

Sean Wheller

Assembly Manual: Building a Freedom Toaster

Sean Wheller

Unless otherwise expressly stated, all original material of whatever nature created by the contributors of the community, is licensed under the Creative Commons [<http://creativecommons.org/>] license Share-Alike [<http://creativecommons.org/licenses/by-sa/2.5/>].

What follows is a copy of the "human-readable summary" of this document. The Legal Code (full license) may be read here [<http://creativecommons.org/licenses/by-sa/2.5/legalcode>].

You are free:

- to copy, distribute, display, and perform the work
- to make derivative works
- to make commercial use of the work

Under the following conditions:



Attribution. You must give the original author credit.



Share Alike. If you alter, transform, or build upon this work, you may distribute the resulting work only under a license

identical to this one.

- For any reuse or distribution, you must make clear to others the license terms of this work.
- Any of these conditions can be waived if you get permission from the copyright holder.

Your fair use and other rights are in no way affected by the above.

This is a human-readable summary of the Legal Code (the full license) [<http://creativecommons.org/licenses/by-sa/2.5/legalcode>].

Table of Contents

1. Introduction	1
Scope	1
Prerequisites	1
Associated Documentation	1
Tools Required	1
Bill of Materials	2
First Angle Autographic	3
2. Material Preparation	4
Housing roof-plate	4
Monitor Angle-bracket	5
Housing Base-plate	6
3. Electrical Wiring	8
4. Assembly	9
Housing Assembly	9
Computer Assembly	9

Chapter 1. Introduction

A Freedom Toaster is physically comprise of the items listed in the section called "Bill of Materials" [2]. Majority of the parts listed are off-the-shelf consumer products. They can be sources from building, electrical or computer supply stores. A few of the parts are bespoke items. In order to assemble a Freedom Toaster raw materials will need to be fashioned to specification.

Scope

This document explains how to assemble the physical housing and computer equipment that comprise a Freedom Toaster, it also provides the specifications and instructions required in order to make those parts that are bespoke and cannot be bought from a supply-store.

Please note that this document does not include instructions on how to install, configure or maintain any of the software components of the Freedom Toaster. For information on these and other subjects that may be of interest to a Freedom Toaster guardian see the section called "Associated Documentation" [?].

Prerequisites

Building a Freedom Toaster requires basic workshop skills and the application of logic. No further skills are required.

Associated Documentation

The following documents are associated with this document:

Installation Manual	Explains how to install and configure the software components of the Freedom Toaster from scratch.
Maintenance Manual	Explains how to perform routine maintenance tasks such as checking and gathering statistics, upgrading Freedom Toaster software, and loading new Freedom Toaster content.
Customization Manual	Explains how the layout and design of the Freedom Toaster software Graphical User Interface and its functionality can be modified to meet new requirements.
User Manual	Explains how navigate the Freedom Toaster Graphical User Interface and how to complete the task of selecting and burning digital content or software to CD or DVD media.

Tools Required

- 1 X Philips Screw Driver
- 1 X Flat Head Screw Driver
- Hammer
- Contact Glue
- Allen Key 4-5/32"
- Spot Welder
- Circular Saw

- 250ml Silver Metallic Paint
- 1 inch Paint Brush
- HB Pencil
- 1 meter length of string

Bill of Materials

Before proceeding please ensure that each of the items listed in the Bills of Materials below are accounted for and available.

Table 1.1. Computer Parts Bill of Materials

Item	Quantity	Notes
AOpen MIDI Tower Chassis with 300W PSU	1	or equivalent
Intel i865G Bayfield motherboard with LAN	1	or equivalent
Intel Pentium4 3.0GHz (1MB)	1	or equivalent
Transcend 512MB400	1	or equivalent
Seagate 120GB Serial ATA Drive	1	or equivalent
Gigabyte CD-Writer	3	or equivalent
IDE Controller Card	1	
IDE and Power extensions	3	
Proline LP-15M04 15" Touch Screen LCD	1	<ul style="list-style-type: none"> • Viewing area 15" TFT • Resolution 800x600 SVGA • Colour 16.7M • Response time (tr/ta) 6/17ms • Contrast ratio 350:1 • Brightness 250 cd/m2 • View angle 120° (H) / 100° (V) • VGA Signal analog VGA



This document does not discuss the software requirements of a Freedom Toaster. Please see the section called "Associated Documentation" [1] for more information.

Table 1.2. Housing Structure Bill of Materials

Item	Quantity	Notes
Baby H Alu Profile (3mm)	2	1.8m
Double H Profile (3mm)	2	1.8m
Aluminium Treadplate	1	1.2m x 1m
12mm Supawood	1	1.2m x 1m
16mm Chipboard (aluminium)	1	1.8m x 700mm
16mm Chipboard (aluminium)	2	1.8m x 300mm
1.5mm Clear UHI	2	1.8m x 502mm
3mm Clear Acrylic	1	1.8m x 672mm

Item	Quantity	Notes
4mm Monitor Bracket	1	
2mm CD ROM Bracket	1	
2mm Mounting Brackets	2	
Vac Form to fit Monitor	1	
Vac Form to fit CD Roms	1	
625mm x 18W Light Fittings	6	
Metal Cover for top	1	
Reverse print side panels	2	1.8m x 502mm
Reverse print front panel	1	1.8m x 672mm
Laser Cut Treadplate	1	
Router Cut Front Panel	1	

First Angle Autographic

Figure 1.1. First Angle Diagram

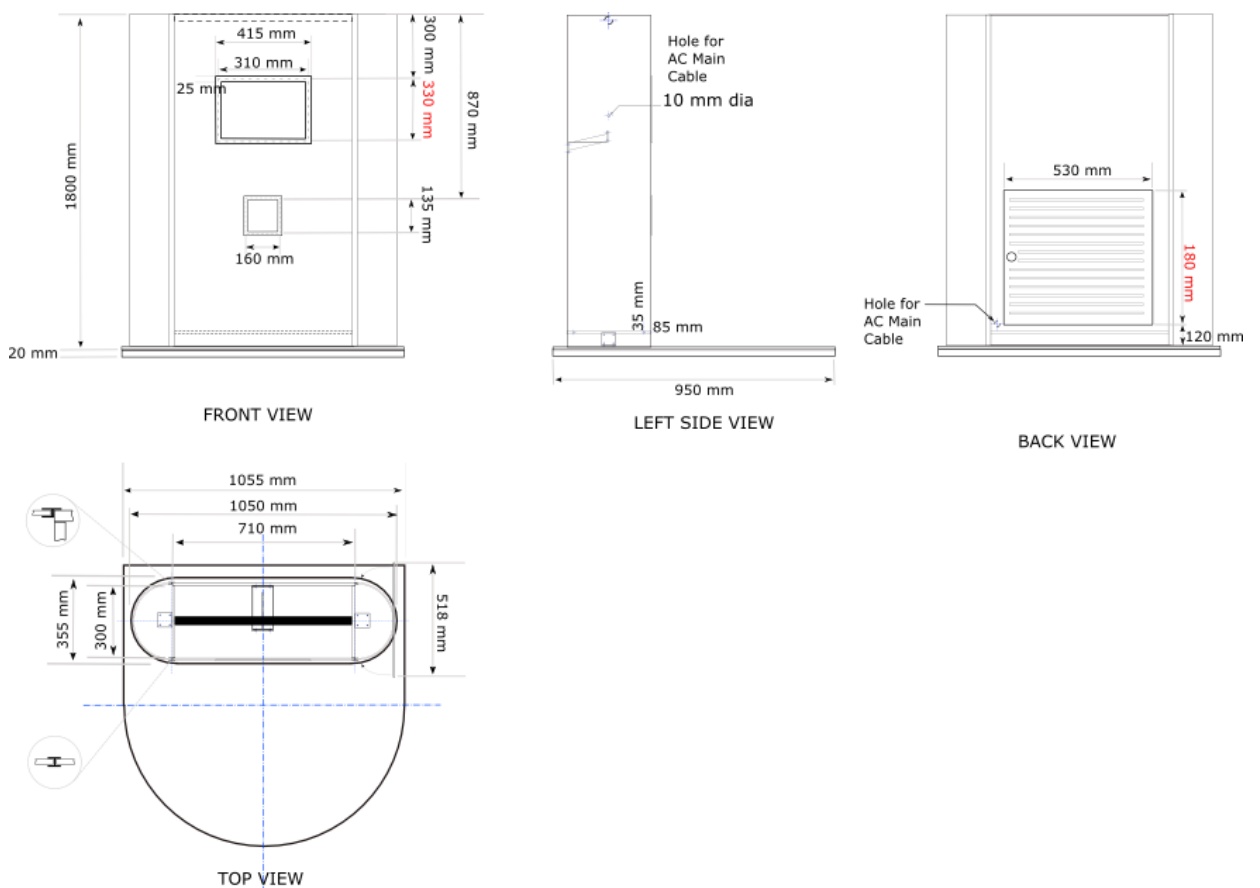

Chapter 2. Material Preparation

This chapter explains how to custom build specific parts for the Freedom Toaster, including:

- Housing roof-plate [4]
- Monitor Angle-bracket [5]
- Housing Base-plate [6]

In manufacturing these items you may wish to use the services of a person or company with workshop facilities.

Housing roof-plate

The Housing roof-plate is made from sheet metal.

Using the measurements in the following diagram, follow the procedures below.

Figure 2.1. Housing roof-plate (First Angle)

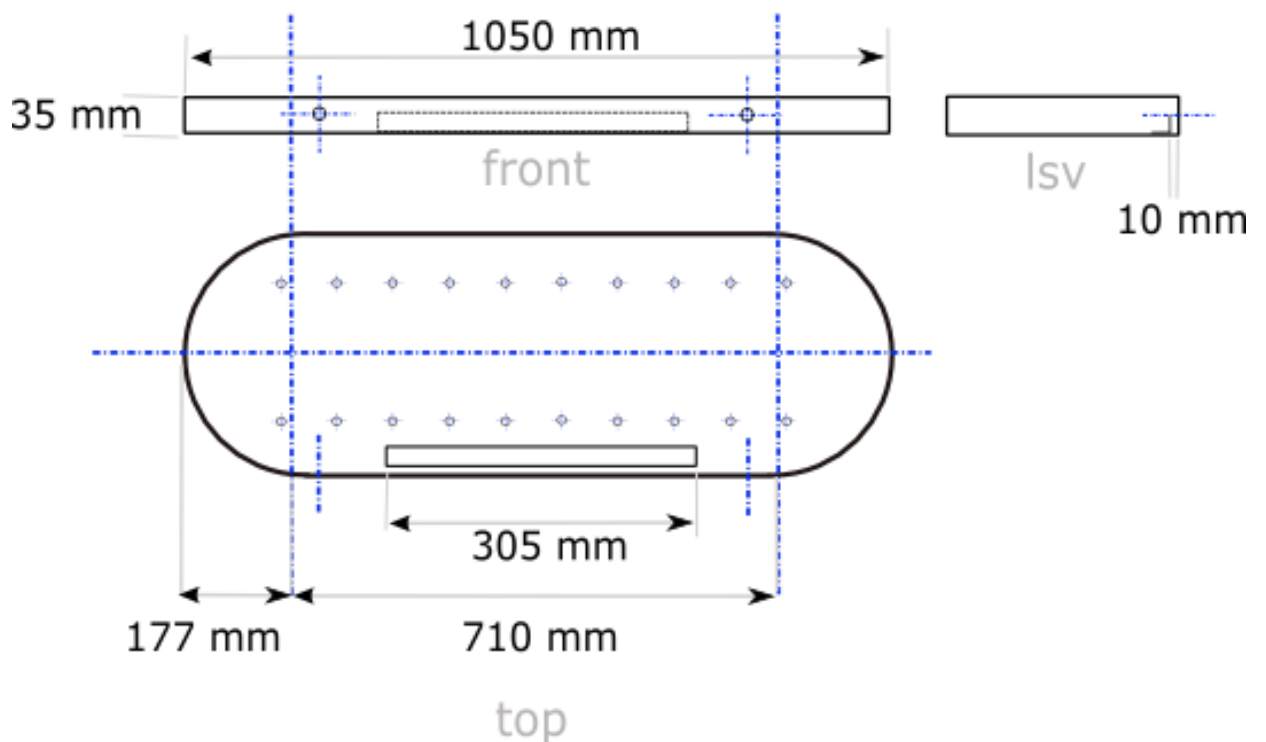

Building the Housing roof-plate

1. Make the roof-plate.
 - a. Start with a rectangular piece of sheet metal width 425mm, length 2250.5mm long.
 - b. Draw a line 35mm along each side of the length.
 - c. Carefully cut the lengths from each side, preserving them for use as the roof-plate rim.

- d. Draw a line 355mm on either side of the length center line of the remaining rectangle.
 - e. Draw a line at 177.5 through the width along the length of the rectangle.
 - f. Using the intersecting lines as the center, draw arc at either end touching the sides.
 - g. Trim away the excess material outside of both arcs.
2. Make the roof-plate rim.
 - Join the two 35mm strips produced in the previous step, to form a single strip 2230.531mm in length.
 3. Spot weld the roof-plate rim to the roof-plate.
 - Starting at the a center, spot-weld the roof-plate rim at 90 degree angle to the circumference edge of the roof-plate.
 4. Finishing
 - a. Use a file to smooth and flatten the joint edges.
 - b. Paint with metallic paint.

Monitor Angle-bracket

The monitor bracket is made from 4mm steel.

Using the measurements in the following diagram, follow the procedures below.

Figure 2.2. Monitor Angle-bracket (First Angle)

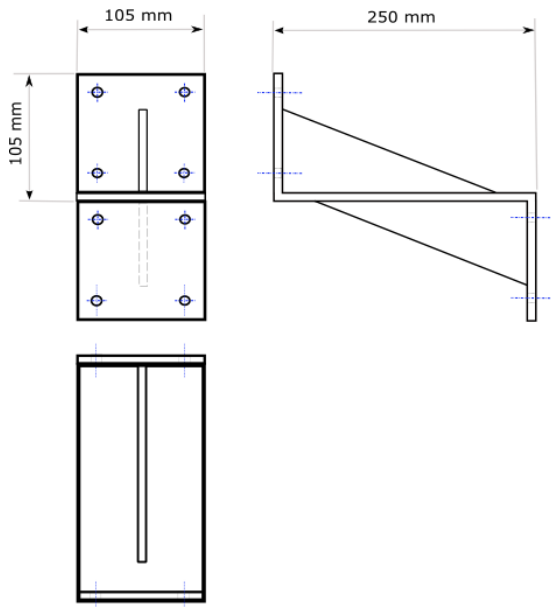

Building the Monitor Angle-bracket

1. Start with a piece of 4mm thick steel ??mm in length, ??mm in width.

2. ...

Housing Base-plate

The Housing Base-plate is comprised of two materials:

- Aluminum Tread plate
- Chip Board

Using the measurements in the following diagram, follow the procedures below.

Figure 2.3. Housing Base-Plate (First Angle)

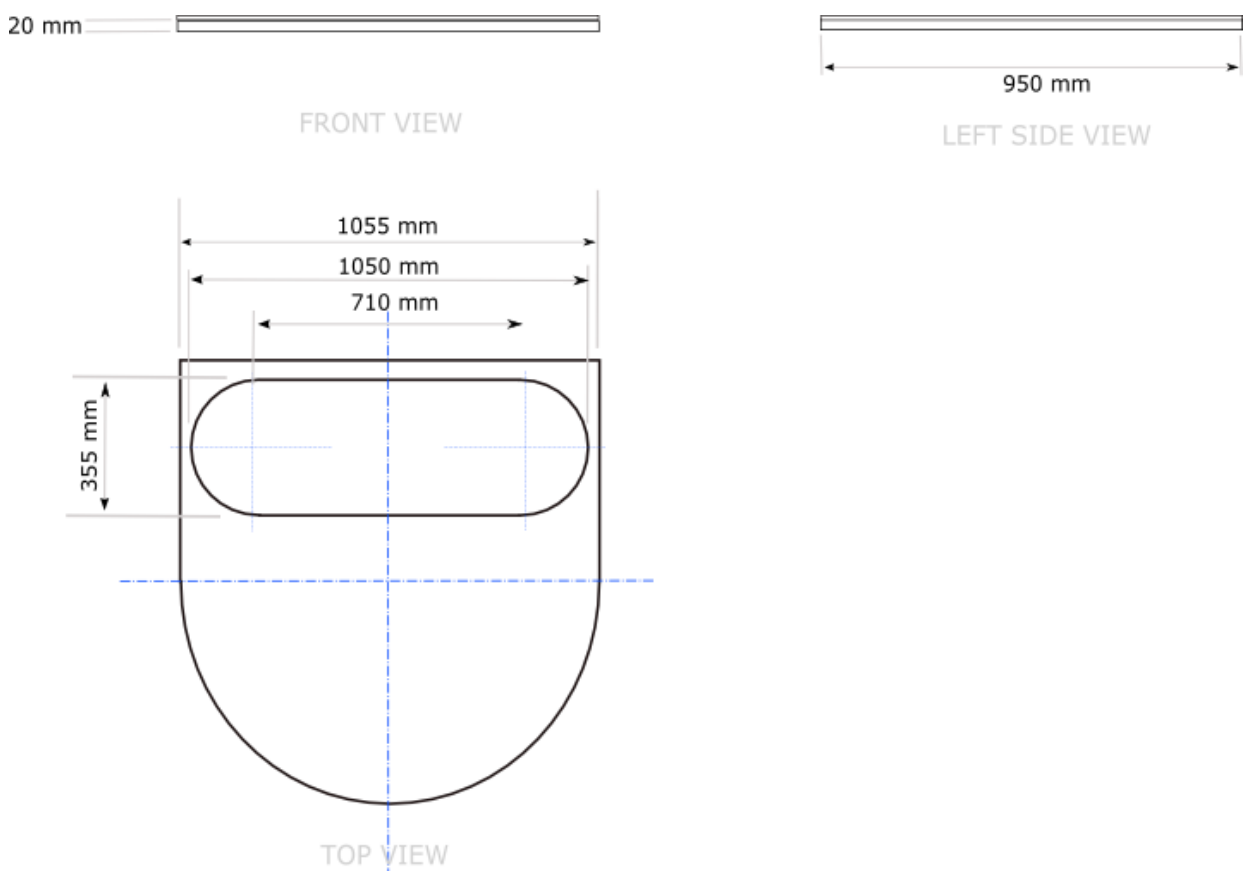

Building the Housing Base-Plate

1. Create the basic shape.
 - a. Cut materials into a rectangle of width 1055 mm, length 950 mm.
 - b. From the center point draw an arc across one edge of the width.
 - c. Cut away excess material to form the curved edge.
2. Create the hole in the tread plate.
 - a. Draw a line 50mm from the straight edge along the width.

-
- b. Draw a line 227.5mm from the straight edge along the width.
 - c. Draw a line 405mm from the straight edge along the width.
 - d. Draw a line 355mm on each side of the width center-line along the length.
 - e. Draw a line 525mm on each side of the width center-line along the length.

You should see a rectangle.

- f. Use the intersection where the line at 227.5mm crosses the two 355mm lines, draw arcs on each end and inside the borders of the marked rectangle.
 - g. Cut away the center shape.
3. Secure the tread plate to the chip board using contact glue and pop-rivets.
 - a. Match the basic shape and bond the tread plate on top of the chip board.
 - b. Drill a hole through the tread plate around the edge at the top of the arc, each corner and at the edge-points where the arch and straight edges meet.
 - c. From the tread plate side, insert a pop-rivet into each hole.



Instead of cutting by hand using a circular saw, use a laser cutting tool.

Chapter 3. Electrical Wiring

The electrical wiring circuit is comprised of:

- Six 625mm x 18W fluorescent light fittings.
- One 3-point adapter.
- ?? meters 3-core electrical cable.

Figure 3.1. Electrical Wire Diagram

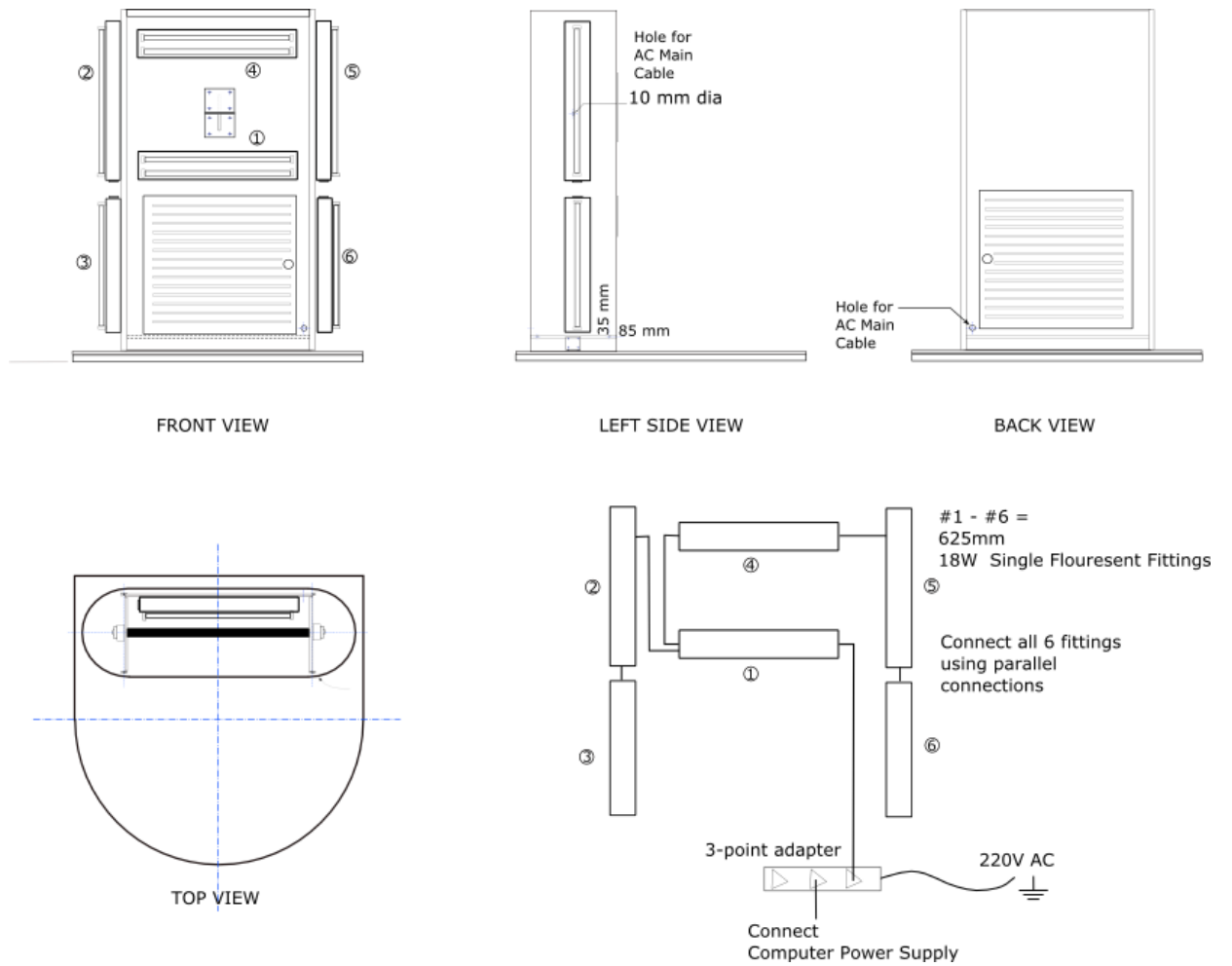

Chapter 4. Assembly

...

Housing Assembly

...

Computer Assembly

This section explains how to connect the CD/DVD devices and Hard Disk Drive for a working Freedom Toaster hardware configuration. The figure below depicts a computer motherboard and the CD/DVD device and Hard Disk Drive that need connecting.

Figure 4.1. Computer Assembly (Reference)

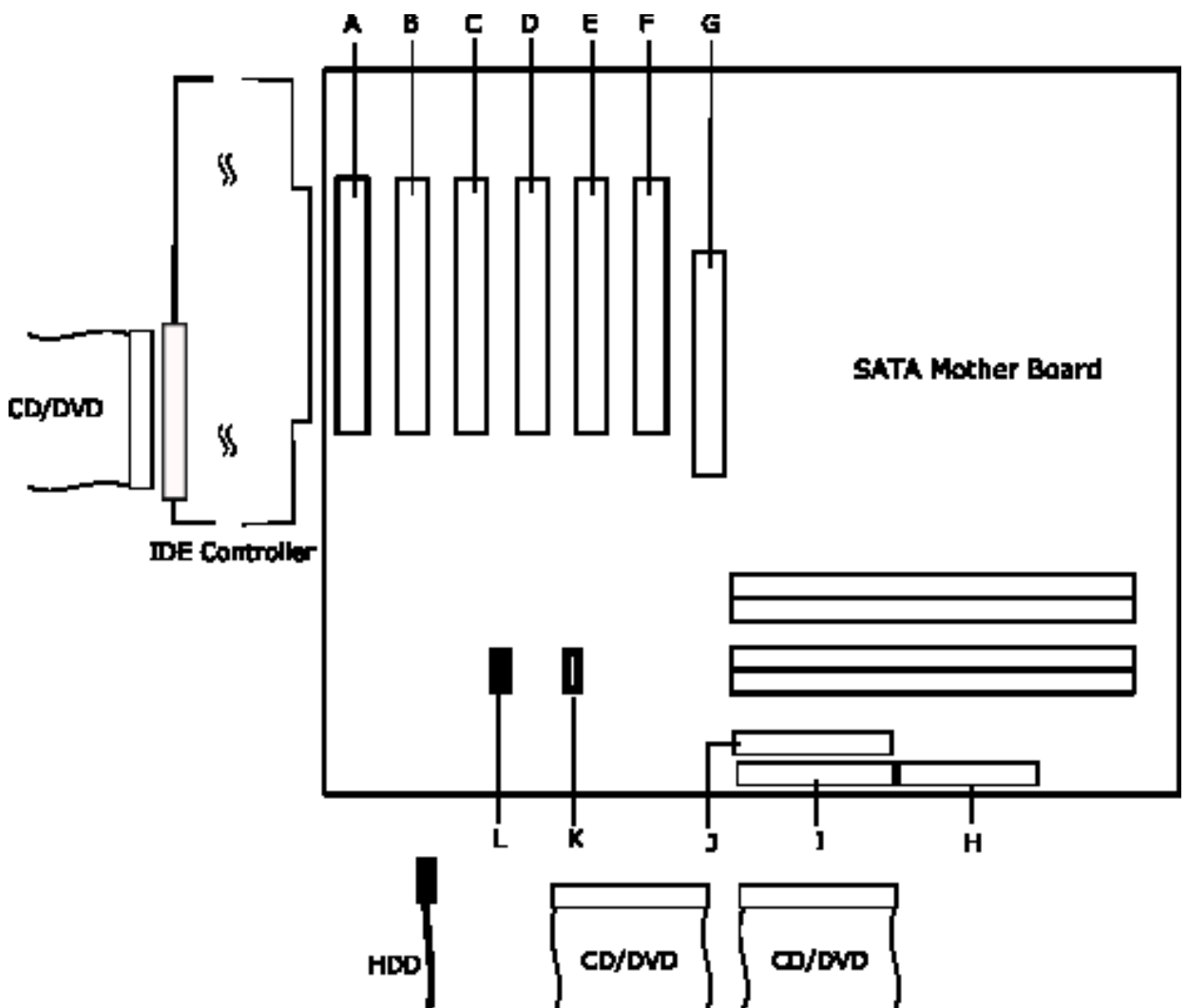

Table 4.1. Computer Assembly (Reference)

Item	Description	Item	Description
A	PCI bus connector 6 Insert IDE Controller Card. Connect third CD/DVD device to IDE controller card	G	AGP connector
B	PCI bus connector 5	H	Diskette drive
C	PCI bus connector 4	I	Primary Parallel ATA IDE Connect first CD/DVD device
D	PCI bus connector 3	J	Secondary Parallel ATA IDE Connect second CD/DVD device
E	PCI bus connector 2	K	Serial ATA connector 1
F	PCI bus connector 1	L	Serial ATA connector 0 Connect Hard Disk Drive (HDD)

Connecting CD/DVD and HDD

1. Insert the IDE controller card into a free PCI slot (see A).
2. Connect the HDD to SATA connector 0 (see L).
3. Connect first CD/DVD device to the Primary Parallel ATA IDE (see I).
4. Connect the second CD/DVD device to the Secondary Parallel ATA IDE (see J).
5. Connect the third CD/DVD device to the IDE controller card interface.